

VESDA ECO™ Detector

Gas Detection and Environmental Monitoring

Gas Detection and Air-sampling Smoke Detection Plus Environmental Monitoring

Expanding on the market-leading VESDA air-sampling smoke detection (ASD) technology, Xtralis has developed the industry's first system to combine ASD with gas detection and environmental monitoring.

VESDA ECO by Xtralis provides protection from both fire and gas threats in powerful yet cost-effective configurations to provide point, zone or total-area coverage in battery-charging rooms, underground utility tunnels, boiler rooms, warehouses, manufacturing facilities, parking garages, transportation centers, and a variety of other applications.

How It Works

VESDA ECO uses an existing VESDA air-sampling pipe network to actively monitor for gas leaks and continuously ensure air quality in occupied areas. **This simple expansion requires no construction and does not involve installing electrical conduit.**

ECO reliably detects unseen hazards by conditioning or filtering the air to remove moisture, interferent¹ gases, dirt and other particulates that can cause traditional point gas detection systems to false alarm or become contaminated.

The VESDA ECO detector is configured using Xtralis VSC configuration software and can be monitored using Xtralis VSM4 monitoring software. Both VSC and VSM can be used to download data from the on-board memory card for data analysis and trending of historical data.

Integration with other building systems, including fire alarm control panels, PLCs, HVAC and building management systems, provides real-time situational awareness for intelligent emergency response. For example, VESDA ECO can be used in a transportation hub to monitor carbon monoxide and nitrogen dioxide levels, activating variable-speed fans as part of a demand-controlled ventilation system, which controls costs and saves energy.

Monitor Two Gases with Each VESDA ECO Detector

Each ECO gas detector can house up to two gas sensors, and additional detectors can be added easily to the VESDA pipe network to monitor more gases if required. Pre-calibrated sensor cartridges are easily replaced in the field and make converting to different gas sensors or replacing sensors a simple task.

With VESDA ECO by Xtralis, you can proactively protect your facility with early warning fire and gas detection and maintain enterprise air quality – with significant costs savings and more reliable results over traditional gas detectors.

Hazardous area certified variants of VESDA ECO are available (Approval pending).



Features

- Cost effectively installs on existing VESDA ASD pipe network
- Centralized monitoring for real-time awareness
- Each VESDA ECO detector is pre-configured with one or two sensors
- Simple expansion to monitor multiple gases
- Integrates with PLCs/HVAC/BMS/FACP
- Simple inline installation
- RS485 Modbus output
- Configurable relays
- 4-20 mA analog outputs
- On-board data logging

Approvals

CE

Electrical safety:

Conforms to ANSI/UL Std 61010-1
Certified to CAN/CSA Std C22.2 No. 61010-1
EN 61010-1

EMC:

FCC 47CFR Part 15B class B
ICES 003
EN 50270

Others:

LCPB, VdS, AFNOR compatible for use with Xtralis EN54-20 approved ASD
LOM approved to UNE 23300 (CO & CO+NO₂)
AQISQ – CMC Pattern Approval (pending)
CCCF – CFE, GB:15322.1 (pending)
Hazardous area, ATEX, IEC Ex, ANSI/ISA, CSA (pending)

1) Consult with Xtralis if application requires removal of interferent gases.

VESDA ECO™ Detector

Gas Detection and Environmental Monitoring

VESDA ECO part number structure

Detectors complete with sensors:

ECO-D-B-AA

A VESDA ECO detector complete with a single gas sensor cartridge. Substitute AA with sensor gas code from table below.

ECO-D-B-AA-BB

A VESDA ECO detector complete with a dual gas sensor cartridge. Substitute AA & BB with sensor gas codes.

See available dual sensor combinations from the table below.

Replacement sensor cartridges:

ECO-SC-AA

A VESDA ECO replacement single gas sensor cartridge. Substitute AA with sensor gas code from table below.

ECO-SC-AA-BB

A VESDA ECO replacement dual gas sensor cartridge. Substitute AA & BB with sensor gas codes.

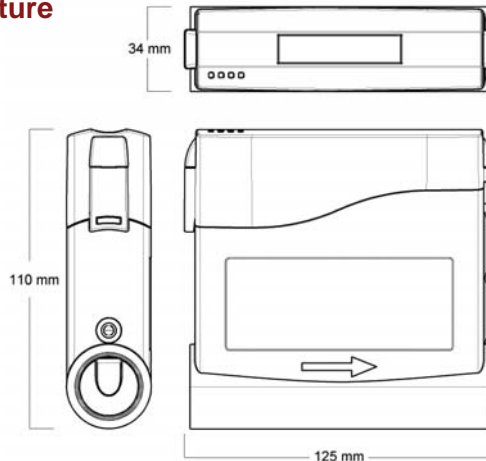

Specifications

Supply Voltage	18-30 VDC
Power Consumption @ 24 VDC	3.2 W
Current Consumption	Typically 60 mA @ 24 V DC for a dual gas (flammable / toxic) quiescent. 85 mA when in alarm.
Dimensions (WHD)	1.3" x 4.9" x 4.4" (34 mm x 125 mm x 110 mm)
Weight	0.6 pounds (250 g)
IP/NEMA ratings	IP65 and NEMA 4
Operating Conditions	Detector Ambient: -4 to 131°F (-20 to 55°C) Sampled Air: -4 to 131°F (-20 to 55°C) Humidity: 10-95% RH, non-condensing
Pipe Size	External Diameter 25mm (EU), 3/4" (US/CAN)
Wire/Terminal size	1.5 mm ² 16 AWG maximum, shielded twisted pair
Cable Access and Termination	2xM16 bulkhead grommets
Accuracy	+/- 5%
Outputs	4 wire RS 485 Modbus RTU (2 wire data comms + 2 wire power) Four (4) programmable relays 30 VDC 1A One (1) 4-20 mA output per sensor
Onboard Memory Card	Micro SD card 2 GB

Dual Sensor Combinations		Sensor 2 Gas Code (BB)									
Sensor 1 Gas Code (AA)		11	12	13	14	31	41	42	43	44	45
11	Hydrogen (H ₂) 0-100% LFL					✓					
12	Methane (CH ₄) 0-100% LFL					✓	✓		✓		
13	Propane (C ₃ H ₈) 0-100% LFL										
14	Hydrogen (H ₂) 0-2000 ppm					✓					
31	Oxygen 0-25% Vol			✓			✓				
41	Carbon Monoxide (CO) 0-500 ppm								✓		✓
42	Ammonia (NH ₃) 0-100 ppm										
43	Hydrogen Sulphide (H ₂ S) 0-100 ppm										
44	Sulphur Dioxide (SO ₂) 0-10 ppm										
45	Nitrogen Dioxide (NO ₂) 0-10 ppm										

Installation

VESDA ECO is designed to press fit onto VESDA air-sampling pipe work. To fit VESDA ECO simply remove a 60 mm section of pipe when using 25 mm OD air-sampling pipe work or 4" for 3/4" BSP pipe.

VESDA ECO provides total flexibility to install one or more detectors anywhere on the pipe network to enable monitoring of a specific point, zone or total area.

www.xtralis.com

The Americas +1 781 740 2223 Asia +852 2916 8894 Australia and New Zealand +61 3 9936 7000
Continental Europe +32 56 24 19 51 UK and the Middle East +44 1442 242 330

The contents of this document are provided on an "as is" basis. No representation or warranty (either express or implied) is made as to the completeness, accuracy or reliability of the contents of this document. The manufacturer reserves the right to change designs or specifications without obligation and without further notice. Except as otherwise provided, all warranties, express or implied, including without limitation any implied warranties of merchantability and fitness for a particular purpose are expressly excluded.

This document includes registered and unregistered trademarks. All trademarks displayed are the trademarks of their respective owners. Your use of this document does not constitute or create a licence or any other right to use the name and/or trademark and/or label.

This document is subject to copyright owned by Xtralis AG ("Xtralis"). You agree not to copy, communicate to the public, adapt, distribute, transfer, sell, modify or publish any contents of this document without the express prior written consent of Xtralis.
Doc. 18912_06

VESDA ECO™
by xtralis™